

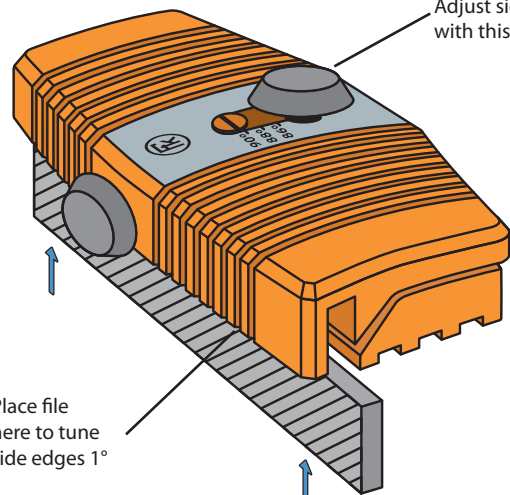

3104 VARIABLE SIDE EDGE BEVELER

85° to 90° SIDE EDGE BEVELING



Adjust side edge angle with this set screw.

Place file here to tune side edges 1°

Perfect for tuning or beveling side edges on all skis and snowboards. Easy to use at home, in the shop or on the hill. Tune side edge 85° to 90° with 1° increments.

Comes with 100 mm medium ski file.
Fits DMT diamonds and coarse and fine files, sold separately.



TOOLS MFG. IN GERMANY

RUFFOLO, INC. 2926 75TH ST. KENOSHA, WI 53143 800-877-7025

VISIT THE FK/SKS TOOLS SITE
www.FKTOOLS-US.COM



3104 VARIABLE SIDE EDGE BEVELER

85° to 90° SIDE EDGE BEVELING

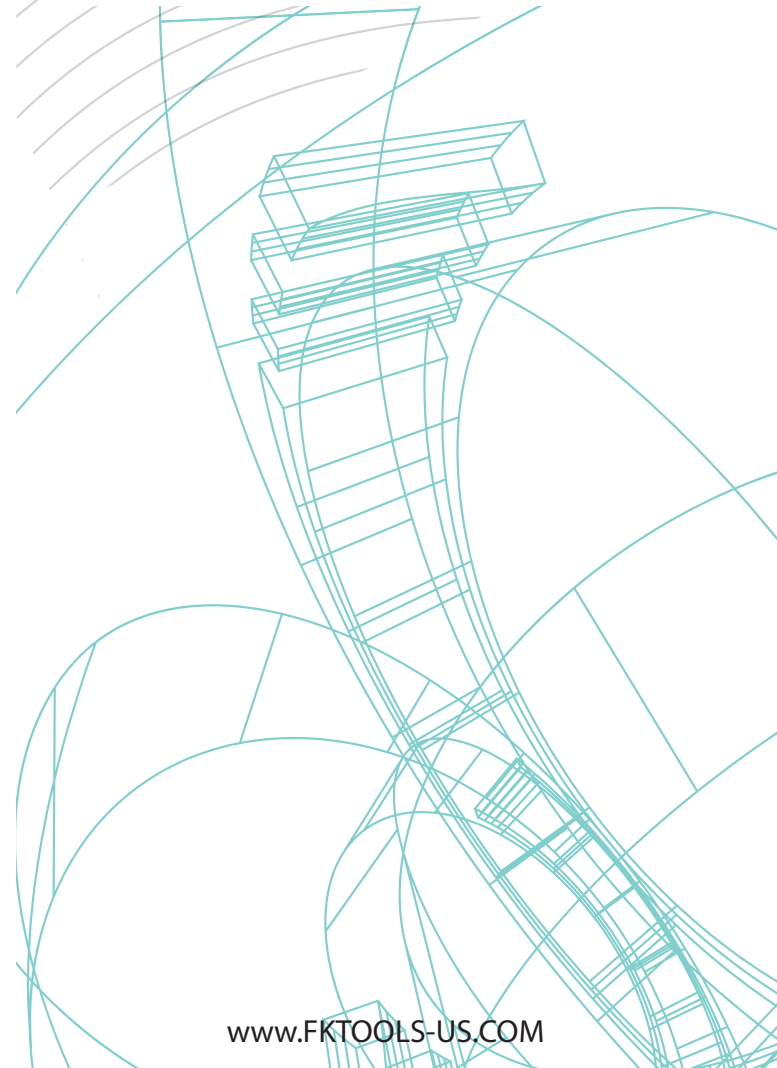

www.FKTOOLS-US.COM

Instructions for using the 3104

To tune the side edge to the angle you desire place the tool on ski or snowboard as shown and adjust the tool to the angle you desire with the thumb-screw.

It is usually best to pull the tool toward you. Notice the arrow on the file and insert it so that the file is inserted into tool with correct cutting direction.

It is usually best to tune the base edge first. You want to just remove the scratches on the base edge.

To produce a new sharp corner work the side edge until enough material is removed to produce a sharp corner.

The 3104 Variable Edge Tuner is designed to accept 100mm or longer files and stones including the DMT 110mm Diamond Stones.

Replacement and optional files

- 3050 100mm Fine file
- 3202 100mm Medium file
- 3208 100mm Mill (Coarse) file
- 519G Green 1200 Grit DMT Diamond
- 519R Red 600 Grit DMT Diamond
- 519B Blue 325 Grit DMT Diamond
- 519K Black 220 Grit Diamond
- 519XX Silver 120 Grit Diamond
- 3214 100mm Tungsten Carbide file
- 3218 100mm Pro Tungsten Carbide file
- 3500 HSX Supersteel file
- 3502 100mm ALL Tungsten Carbide file

3104 VARIABLE SIDE EDGE BEVELER

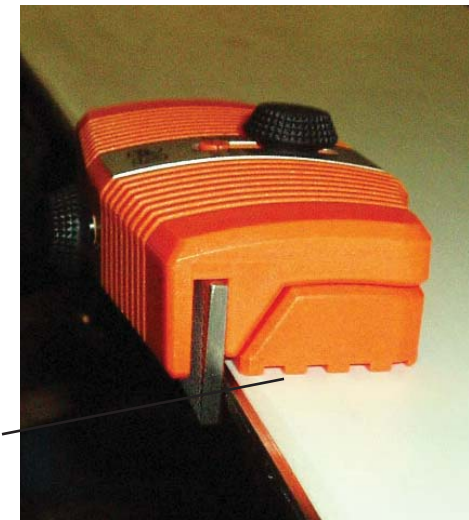
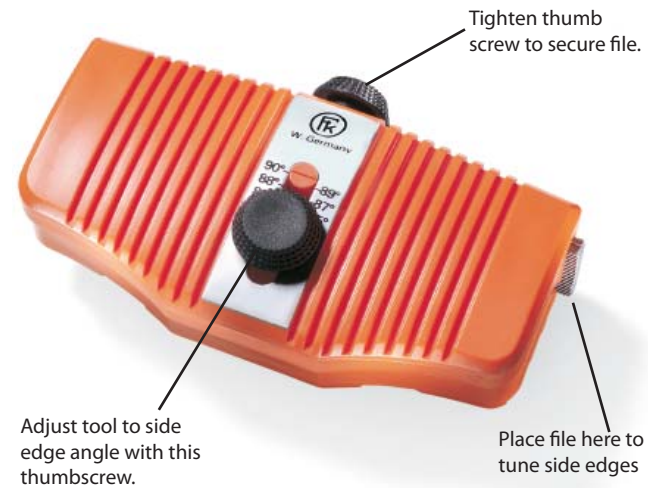

see Tuning tips online at
www.fktools-us.com/tooltips.asp